

# MAC 101™

## RGB, CT, WRM and CLD models User manual



MAC 101



MAC 101 CT



MAC 101 CLD



MAC 101 WRM

# Dimensions

All dimensions are in millimeters

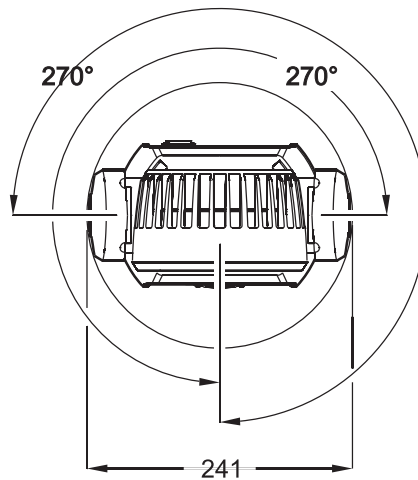
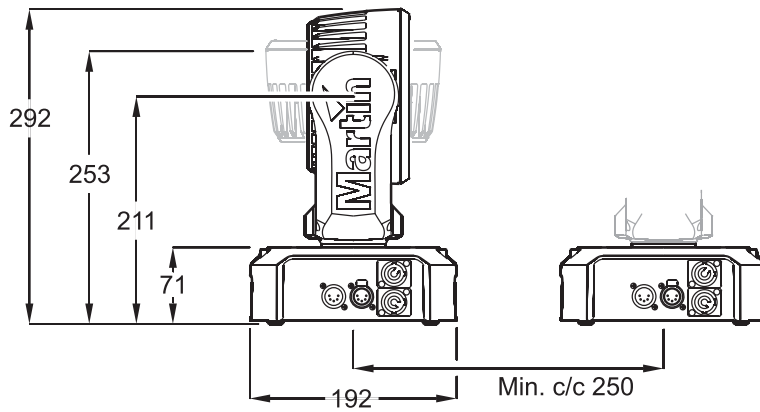
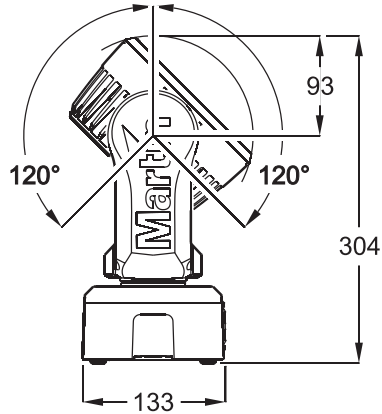

©2010-2011 Martin Professional A/S. Information subject to change without notice. Martin Professional A/S and all affiliated companies disclaim liability for any injury, damage, direct or indirect loss, consequential or economic loss or any other loss occasioned by the use of, inability to use or reliance on the information contained in this manual. The Martin logo, the Martin name and all other trademarks in this document pertaining to services or products by Martin Professional A/S or its affiliates and subsidiaries are trademarks owned or licensed by Martin Professional A/S or its affiliates or subsidiaries. The use of certain patents in MAC 101 products is licensed by Color Kinetics, Inc. (see details printed on product).

# Safety Information



## WARNING!

**Read the safety precautions in this section before installing, powering, operating or servicing this product.**

The following symbols are used to identify important safety information on the product and in this manual:



**DANGER!**  
Safety hazard.  
Risk of severe injury or death.



**DANGER!**  
Hazardous voltage. Risk of lethal or severe electric shock.



**WARNING!**  
Fire hazard.



**WARNING!**  
LED light emission. Risk of eye injury.



**WARNING!**  
Burn hazard. Hot surface. Do not touch.



**WARNING!**  
Wear protective eyewear.



**WARNING!** Refer to user manual.



**Warning! Risk Group 3 (high risk) LED product according to EN 62471. Do not look into the beam at a distance of less than 8.3 meters (27 ft. 3 inches) from the front surface of the product. Do not view the light output with optical instruments or any device that may concentrate the beam.**



This product is for professional use only. It is not for household use.

This product presents risks of severe injury or death due to fire and burn hazards, electric shock and falls.



**Read this manual** before installing, powering or servicing the fixture, follow the safety precautions listed below and observe all warnings in this manual and printed on the fixture. If you have questions about how to operate the fixture safely, please contact your Martin supplier or call the Martin 24-hour service hotline on +45 8740 0000, or in the USA on 1-888-tech-180.



## PROTECTION FROM ELECTRIC SHOCK

- Disconnect the fixture from AC power before removing or installing any cover or part and when not in use.
- Always ground (earth) the fixture electrically.
- Use only a source of AC power that complies with local building and electrical codes and has both overload and ground-fault (earth-fault) protection.
- Before using the fixture, check that all power distribution equipment and cables are in perfect condition and rated for the current requirements of all connected devices.
- Power input and throughput cables must be rated 20 A minimum, have three conductors 1.5 mm<sup>2</sup> (16 AWG) minimum conductor size and an outer cable diameter of 5 - 15 mm (0.2 - 0.6 in.). Cables must be hard usage type (SJT or equivalent) and heat-resistant to 90° C (194° F) minimum. In the EU the cable must be HAR approved or equivalent.
- Use only Neutrik PowerCon NAC3FCA cable connectors to connect to power input sockets. Use only Neutrik PowerCon NAC3FCB cable connectors to connect to power throughput sockets.
- Isolate the fixture from power immediately if the power plug or any seal, cover, cable, or other component is damaged, defective, deformed, wet or showing signs of overheating. Do not reapply power until repairs have been completed.

- Do not expose the fixture to rain or moisture.
- Refer any service operation not described in this manual to a qualified technician.
- Socket outlets used to supply MAC 101 fixtures with power or external power switches must be located near the fixtures and easily accessible so that the fixtures can easily be disconnected from power.



## PROTECTION FROM BURNS AND FIRE



- Do not operate the fixture if the ambient temperature ( $T_a$ ) exceeds  $40^\circ\text{C}$  ( $104^\circ\text{F}$ ).
- The exterior of the fixture becomes hot during use. Avoid contact by persons and materials. Allow the fixture to cool for at least 10 minutes before handling.
- Keep all combustible materials (e.g. fabric, wood, paper) at least 100 mm (3.9 in.) away from the head.
- Keep flammable materials well away from the fixture.
- Ensure that there is free and unobstructed airflow around the fixture.
- Do not illuminate surfaces within 200 mm (7.9 ins.) of the MAC 101.
- Do not attempt to bypass thermostatic switches or fuses.
- If you relay power from one fixture to another using power throughput sockets, do not connect more than ten MAC 101 fixtures in total to each other in an interconnected chain.
- Connect only other MAC 101 fixtures to MAC 101 power throughput sockets. Do not connect any other type of device to these sockets.
- Do not stick filters, masks or other materials onto any optical component.
- Do not modify the fixture in any way not described in this manual
- Install only genuine Martin parts.



## PROTECTION FROM INJURY



- Do not look continuously at LEDs from a distance of less than 8.3 meters (27 ft. 3 inches) from the front surface of the fixture without protective eyewear such as shade 4-5 welding goggles. At less than this distance, the LED emission can cause eye injury or irritation. At distances of 8.3 meters (27 ft. 3 inches) and above, light output is harmless to the naked eye provided that the eye's natural aversion response is not overcome.
- Do not look at LEDs with magnifiers, telescopes, binoculars or similar optical instruments that may concentrate the light output.
- Ensure that persons are not looking at the LEDs from within 8.3 meters (27 ft. 3 inches) when the product lights up suddenly. This can happen when power is applied, when the product receives a DMX signal, or when **SERVICE** menu items are selected.
- Fasten the fixture securely to a fixed surface or structure when in use. The fixture is not portable when installed.
- Ensure that any supporting structure and/or hardware used can hold at least 10 times the weight of all the devices they support.
- If suspending from a rigging structure, fasten the fixture to a rigging clamp with an M12 bolt screwed into the threaded hole in the center of the base of the fixture. The bolt must protrude at least 20 - 30 mm (0.8 - 1.2 ins.) into the fixture. If the fixture is suspended by any other method, an M12 bolt must be tightened into this hole so that it protrudes at least 20 - 30 mm (0.8 - 1.2 ins.) into the fixture.
- If the fixture is installed in a location where it may cause injury or damage if it falls, install as described in this manual a secondary attachment such as a safety cable that is approved by an official body such as TÜV as a safety attachment for the weight that it secures. The safety cable must comply with EN 60598-2-17 Section 17.6.6 and be capable of bearing a static suspended load that is ten times the weight of the fixture and all installed accessories.
- Allow enough clearance around the head to ensure that it cannot collide with an object or another fixture when it moves.
- Check that all external covers and rigging hardware are securely fastened.
- Block access below the work area and work from a stable platform whenever installing, servicing or moving the fixture.
- Do not operate the fixture with missing or damaged covers, shields or any optical component.

# Contents

Dimensions .....	2
Safety Information.....	3
Fixture overview .....	6
Introduction .....	7
Using for the first time .....	7
AC power .....	8
Power voltage .....	8
Power cables and power plug .....	8
Relaying power to other devices .....	9
Data link .....	10
Tips for reliable data transmission .....	10
Connecting the data link .....	10
Physical installation .....	11
Fastening the fixture to a flat surface.....	11
Mounting the fixture on a truss .....	11
Hanging the fixture.....	12
Quick-mount surface mounting bracket .....	12
Setup.....	13
Control panel and menu navigation.....	13
DMX address setting .....	13
DMX modes in the standard MAC 101 .....	13
Tailoring performance .....	14
Restoring factory default settings .....	15
Operation and effects .....	16
Service and maintenance.....	18
Cleaning.....	18
Control menu service utilities.....	19
Fixture readouts.....	20
Lubrication .....	20
Installing optional diffuser filters.....	21
Installing an optional top hat .....	21
DMX protocols .....	22
Standard MAC 101 RGB DMX protocol.....	22
MAC 101 CT DMX protocol.....	24
MAC 101 CLD and MAC 101 WRM DMX protocol .....	25
LEE colors and RGB equivalents .....	26
Onboard control menus.....	27
Display messages.....	29
Troubleshooting .....	30
Specifications.....	31

# Fixture overview

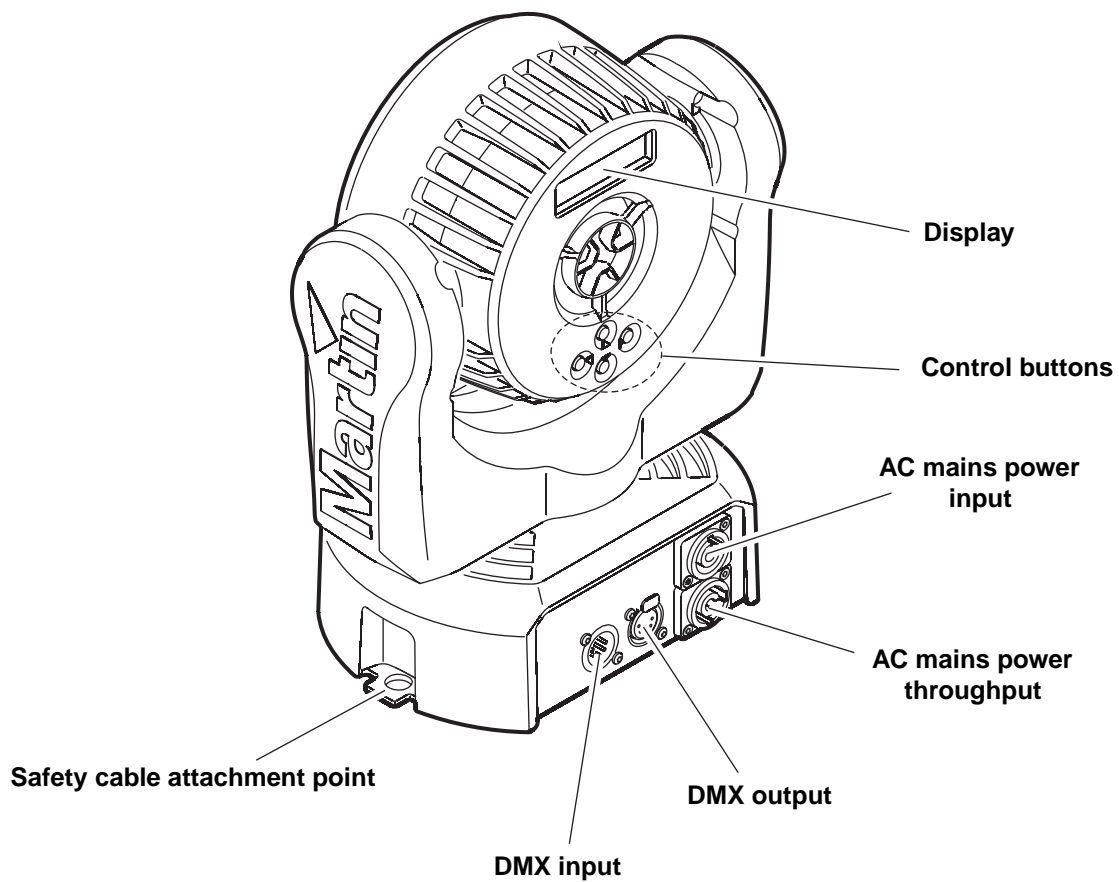

Figure 1: Fixture overview

# Introduction

Thank you for selecting the MAC 101™, an intelligent lighting fixture from Martin Professional™. This range of compact LED-based moving-head washlight includes four models:

**All MAC 101 fixtures** feature:

- DMX control
- Onboard control panel and backlit LCD graphic display
- Smooth electronic dimming
- Electronic shutter with strobe and pulse effects
- 540° pan and 240° tilt ranges

The **standard MAC 101** features:

- RGB color mixing with color temperature control
- Cree XP-E high-power RGB emitters
- 'Color wheel' color-snap feature
- Three DMX control modes:
  - Raw RGB + CTC
  - Calibrated RGB + CTC
  - Basic (color-wheel only, RGB + CTC disabled)

The **MAC 101 CT** features:

- Warm/cold white mixing with 2800 - 6200 K color temperature control
- Cree XP-E high-power warm and cold white emitters

The **MAC 101 WRM** features

- 2800 K color temperature
- Cree XP-E high-power warm white emitters

The **MAC 101 CLD** features:

- 6700 K color temperature
- Cree XP-E high-power cold white emitters

For the latest firmware updates, documentation, and other information about this and all Martin Professional products, please visit the Martin website at <http://www.martin.com>

Comments or suggestions regarding this document may be e-mailed to [service@martin.dk](mailto:service@martin.dk) or posted to: Technical Documentation, Martin Professional A/S, Olof Palmes Allé 18, DK-8200 Aarhus N, Denmark.

## Using for the first time



**Warning!** Read "Safety Information" on page 3 before installing, powering, operating or servicing the MAC 101. Before applying power to the fixture:

- Check the Martin Professional website at [www.martin.com](http://www.martin.com) for the most recent user documentation and technical information about the MAC 101. Martin user manual revisions are identified by the revision letter at the bottom of page 2.
- Carefully review "Safety Information" starting on page 3.
- Check that the local AC mains power source is within the fixture's power voltage and frequency ranges.
- See "Power cables and power plug" on page 8. Install a Neutrik PowerCon NAC3FCA power input connector on a suitable power cable. If drawing power from a mains power outlet, install a suitable power plug on the power cable.

# AC power



**Warning!** Read “Safety Information” starting on page 3 before connecting the MAC 101 to AC mains power.



**Warning!** For protection from electric shock, the MAC 101 must be grounded (earthed). The power distribution circuit must be equipped with a fuse or circuit breaker and ground-fault (earth-fault) protection.

**Warning!** Socket outlets or external power switches used to supply the MAC 101 with power must be located near the fixture and easily accessible so that the fixtures can easily be disconnected from power.

**Important!** Do not insert or remove live Neutrik PowerCon connectors to apply or cut power, as this may cause arcing at the terminals that will damage the connectors.

**Important!** Do not use an external dimming system to supply power to the MAC 101, as this may cause damage to the fixture that is not covered by the product warranty.

The MAC 101 can be hard-wired to a building electrical installation if you want to install it permanently, or a power plug that is suitable for the local power outlets can be installed on the power cable.

## Power voltage





**Warning!** Check that the voltage range specified on the fixture’s serial number label matches the local AC mains power voltage before applying power to the fixture.

MAC 101 fixtures accept AC mains power at 100-240 V nominal, 50/60 Hz. Do not apply AC mains power to the fixture at any other voltage than that specified on the fixture’s serial number label.

## Power cables and power plug

Power input and throughput cables must be rated 20 A minimum, have three conductors 1.5 mm<sup>2</sup> (16 AWG) minimum conductor size and an outer cable diameter of 5 - 15 mm (0.2 - 0.6 in.). Cables must be hard usage type (SJT or equivalent) and heat-resistant to 90° C (194° F) minimum. In the EU the cable must be HAR approved or equivalent.

If you install a power plug on the power cable, install a grounding-type (earthed) plug that is rated 20 A minimum. Follow the plug manufacturer’s instructions. Table 1 shows standard wire color-coding schemes and some possible pin identification schemes; if pins are not clearly identified, or if you have any doubts about proper installation, consult a qualified electrician.

Wire Color (EU models)	Wire Color (US models)	Conductor	Symbol	Screw (US)
brown	black	live	L	yellow or brass
blue	white	neutral	N	silver
yellow/green	green	ground (earth)	 or 	green

**Table 1: Wire color-coding and power connections**



## Installing a power input connector on a power cable

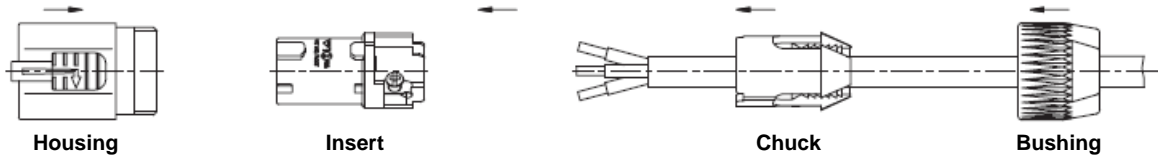

To install a Neutrik PowerCon NAC3FCA input connector on a power cable:

1. Slide the bushing over the cable.
2. Slide the white chuck over cables with a diameter ( $D_a$ ) of 5 - 10 mm (0.2 - 0.4 in.), or the black chuck over cables with a diameter of 10 - 15 mm (0.4 - 0.6 in.).
3. Prepare the end of the cable by stripping 20 mm (0.8 in.) of the cable's outer jacket.
4. Strip 8 mm (1/3 in.) from the end of each of the wires.
5. Insert each of the wire ends into the appropriate terminal (see instructions and Table 1 above) and fasten the clamping device using a small flathead screw driver.
6. Push and insert the chuck into the housing (note that there is a raised key on the chuck to ensure that it is oriented correctly).
7. Fasten the bushing using a wrench to a torque of 2.5 Nm (1.8 lb.-ft).

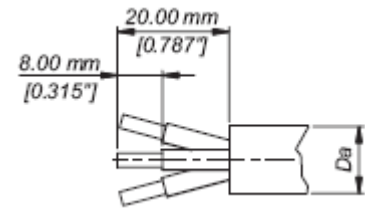

Cable end

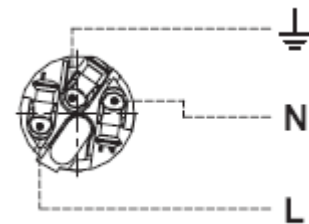

Terminals

Illustrations above used by kind permission of Neutrik AG

## Relaying power to other devices



**Warning! Do not connect more than ten MAC 101 fixtures in total to AC mains power in one interconnected chain.**

Power can be relayed to another device via the light-grey PowerCon throughput socket that accepts a light-grey PowerCon NAC3FCB cable connector. Note that blue input and light-grey throughput connectors have different designs: one type cannot be connected to the other. Neutrik power connectors can be ordered separately from Martin (see Accessories on page 33).

If you link fixtures in a chain so that they all draw AC mains power via the first fixture, certain points must be respected:

- A hard usage, three-conductor, 16 AWG or 1.5 mm<sup>2</sup> cable with SJT or equivalent cable jacket must be used to connect the first fixture to AC mains power and to interconnect all the fixtures in the chain up to a maximum of seven fixtures in total.
- Light-grey Neutrik PowerCon NAC3FCB connectors must be used to draw AC mains power from the fixtures' power throughput sockets and blue Neutrik PowerCon NAC3FCA connectors must be used to supply power at the fixture's power input sockets.
- No matter what the AC mains power voltage is, *do not connect more than ten MAC 101 fixtures in total* (i.e. including the first fixture) to AC mains power in one interconnected daisy chain using power input and throughput connectors.

# Data link

A DMX 512 data link is required in order to control a MAC 101 via DMX.

The MAC 101 has 5-pin XLR connectors for DMX data input and output. The pin-out on all connectors is pin 1 = shield, pin 2 = cold (-), and pin 3 = hot (+). Pins 4 and 5 in the 5-pin XLR connectors are not used in the MAC 101 but are available for possible additional data signals as required by the DMX512-A standard. Standard pin-out is pin 4 = data 2 cold (-) and pin 5 = data 2 hot (+).

The MAC 101 is not subject to the limit of 32 devices per daisy-chained link which is common in Martin fixtures. Instead, the number of fixtures is either limited to 256 or limited by the number of DMX channels required by the fixtures in relation to the maximum 512 channels available in one DMX universe, whichever limit is lower. Note that if independent control of a fixture is required, it must have its own DMX channels. Fixtures that are required to behave identically can share the same DMX channels.

To add more fixtures or groups of fixtures when the above limit is reached, add a DMX universe and another daisy-chained link.

## Tips for reliable data transmission

- Use shielded twisted-pair cable designed for RS-485 devices: standard microphone cable cannot transmit control data reliably over long runs. 24 AWG cable is suitable for runs up to 300 meters (1000 ft). Heavier gauge cable and/or an amplifier is recommended for longer runs.
- Never use both a fixture's outputs to split a DMX link. To split the link into branches, use a splitter such as the Martin 4-Channel Opto-Isolated RS-485 Splitter/Amplifier.
- Terminate the link by installing a termination plug in the output socket of the last fixture. The termination plug, which is a male XLR plug with a 120 Ohm, 0.25 Watt resistor soldered between pins 2 and 3, "soaks up" the control signal so it does not reflect and cause interference. If a splitter is used, terminate each branch of the link.

## Connecting the data link

To connect the MAC 101 to data:

1. Connect the DMX data output from the controller to the closest MAC 101's male 5-pin XLR DMX input connector.
2. Connect the DMX output of the fixture closest to the controller to the DMX input of the next fixture and continue connecting fixtures output to input.
3. Terminate the last fixture on the link with a 120 Ohm resistor.

# Physical installation



**Warning!** The MAC 101 must be either fastened to a flat surface such as a stage or wall, or clamped to a truss or similar structure in any orientation using a rigging clamp. Do not apply power to the MAC 101 if it is standing freely or the fixture can be moved.

**Warning!** If the MAC 101 can cause injury or damage if it falls, attach an approved safety cable to one of the safety cable attachment points on the base (see “Fixture overview” on page 6).

Check that all surfaces to be illuminated are minimum 200 mm (7.9 ins.) from the fixture, that combustible materials (wood, fabric, paper, etc.) are minimum 100 mm (3.9 in.) from the head, that there is free airflow around the fixture and that there are no flammable materials nearby.

Make sure that it is impossible for the moving head to collide with another fixture or other object.

Allow a minimum center-to-center distance of 250 mm (10 ins.) between MAC 101 fixtures.

## Fastening the fixture to a flat surface

The MAC 101 can be fastened to a fixed flat surface that is oriented at any angle. Check that the surface can support at least 10 times the weight of all fixtures and equipment to be installed on it.



**Warning!** The supporting surface must be hard and flat or air vents in the base may be blocked, which will cause overheating. Fasten the fixture securely. Do not stand it on a surface or leave it where it can be moved or can fall over. Attach a securely anchored safety cable to the safety cable attachment point (see “Fixture overview” on page 6) if the fixture is to be installed in any location where it may fall and cause injury or damage if the primary attachment fails.

## Mounting the fixture on a truss

The MAC 101 can be clamped to a truss or similar rigging structure in any orientation.



**Warning!** Use a rigging clamp with an M12 bolt if suspending the fixture from its base. The clamp must be screwed into the central threaded hole in the fixture base. The M12 bolt must protrude 20 - 30 mm (0.8 - 1.2 ins.) into the fixture base.

An M12 bolt that is suitable for many types of rigging clamp is supplied with the MAC 101, but you must pass the bolt through the clamp and check that the distance the bolt will protrude into the fixture base is within the 20 - 30 mm limits before using it. If the bolt is not within these limits, you must find an alternative bolt that is.

To clamp a MAC 101 to a truss:

1. Check that the rigging structure can support at least 10 times the weight of all fixtures and equipment to be installed on it.
2. Obtain a rigging clamp such as the G-clamp (P/N 91602003), Half-coupler clamp (P/N 91602005) or Quick trigger clamp (P/N 91602007)

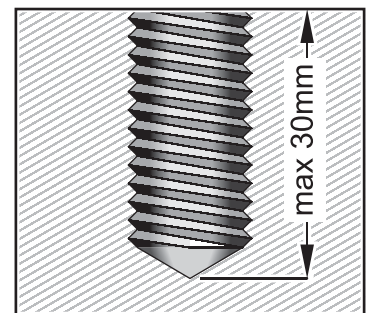
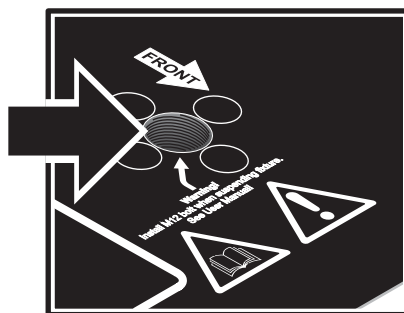

Figure 2: Rigging clamp bolt

- available as accessories from Martin. An omega bracket is not required.
3. Check that the rigging clamp is undamaged and can bear at least 10 times the weight of the fixture. Fasten the clamp to the fixture with a minimum grade 8.8 steel M12 bolt in the threaded hole in the

center of the base of the fixture. The bolt must protrude 20 - 30 mm (0.8 - 1.2 ins.) into the base of the fixture.

4. Block access under the work area. Working from a stable platform, hang the fixture on the truss with the arrow on the base towards the area to be illuminated. Tighten the rigging clamp.
5. Secure the fixture against clamp failure with a secondary attachment such as an approved safety cable that is rated for the weight of the fixture using one of the attachment points at the edges of the base (see "Fixture overview" on page 6). Do not use any other part of the fixture as a safety cable attachment point.
6. Check that the head will not collide with other fixtures or objects.

## Hanging the fixture

In some regions, it may be legal to use two safety cables, one looped through one cable attachment point (see "Fixture overview" on page 6) and the other looped through the other cable attachment point, to suspend the fixture. If one cable fails, the other will provide secondary attachment.

However, this suspension method is not recommended as it will not hold the base firmly, and moving pan and tilt will cause the fixture and light beam to swing uncontrollably. Instead, we strongly recommend installation using a rigging clamp as described above.



**Warning!** If you choose to suspend using two cables anyway, you must install a minimum 8.8 grade steel M12 bolt in the rigging clamp hole in the center of the fixture's base. See Figure 2. The bolt must protrude 20 - 30 mm (0.8 - 1.2 ins.) into the base. If you do not secure the base in this way, there is a risk that the fixture may separate from the base and fall.

## Quick-mount surface mounting bracket

Quick-mount surface mounting brackets (P/N 91606017) for the MAC 101 are available from Martin in sets of 5 brackets. The bracket can be screwed to a surface and the MAC 101 mounted on and removed from the bracket in seconds. A securely anchored safety cable or other secondary attachment must be provided if the bracket is used. Installation instructions are supplied with the brackets.

# Setup



**Warning! Read “Safety Information” on page 3 before installing, powering, operating or servicing the MAC 101.**

## Control panel and menu navigation

The onboard control panel and backlit graphic display are used to set the MAC 101’s DMX address, configure individual fixture settings (personality), read out data and execute service utilities. See “Onboard control menus” on page 27 for a complete list of menus and commands.

### Using the control buttons

- To enter a menu, select a function or apply a selection, press **▶** (Enter).
- Press **▲** (Up) and **▼** (Down) to scroll within a menu or adjust values.
- To escape a function or move back one level in the menu structure, press **◀** (Menu / Escape).

### Control button reset shortcut

- Holding **◀** (Menu/Escape) pressed in and pressing **▲** (Up) forces the fixture to reset.

### Display panel functions

The DMX address is shown in the display panel when the MAC 101 is powered on and has reset.

The display panel backlighting indicates fixture status as follows:

- The display dims to zero during resets.
- The display flashes slowly if the fixture is not receiving a valid DMX signal unless the control buttons are used. In this case, the display behaves normally until the buttons have not been used for a short period, then begins to flash slowly again.
- The display can be set to go into sleep mode via **PERSONALITY** → **DISPLAY** in the control menu. Connecting a DMX signal ‘wakes up’ the display.

## DMX address setting

The DMX address, also known as the start channel, is the first channel used to receive instructions from the controller. For independent control, each fixture must be assigned its own control channels. Two MAC 101 fixtures of the same type may share the same address, however, if identical behavior is desired. Address sharing can be useful for diagnostic purposes and symmetric control, particularly when combined with the inverse pan and tilt options.

The DMX address is configured using the **DMX ADDRESS** menu in the control panel.

## DMX modes in the standard MAC 101

DMX control mode in the standard MAC 101 RGB model is selected in the **CONT MODE** (control mode) menu. The standard MAC 101 provides three DMX control modes:

- **RAW** is an uncalibrated RGB mode that gives maximum output and slightly more saturated color, but there may be inconsistency in color balance between fixtures. It uses 12 DMX channels.
- **RGB** is a calibrated RGB mode that gives slightly less output than **RAW** mode but consistent color balance across fixtures. It uses 12 DMX channels.
- **BASIC** is a basic mode that only uses 8 DMX channels but only gives access to the color wheel effect for color control – RGB and CTC are not available.

**RAW** and **RGB** modes include the same control options as **BASIC** mode, but they provide 4 extra channels to give RGB control and CTC.

See “DMX protocols” on page 22 for details of the DMX commands available in the different modes.

## Tailoring performance

### Pan and tilt movement

The **P/T SPEED** settings set the maximum speed of pan and tilt movement. **FAST** optimizes for speed and **SLOW** optimizes for smoothness of movement. **NORMAL** is the default setting and gives a good compromise between these two.

The **PAN INVERT** and **TILT INVERT** commands reverse the direction of pan and tilt, and the **SWAP** command sends pan commands to tilt and vice versa. These settings are useful for symmetrical effects with multiple fixtures.

### Cooling

**FANS** gives you a choice of two settings:

- The default setting **REGULATED** should suit use in all normal situations and ensure excellent service lifetimes for all components.
- **FULL** maximizes cooling and reduces the operating temperature of the components in the head. It is recommended when the MAC 101 is used intensively in a warm environment or in fixed installations. Note that it will give increased fan noise compared to the other cooling modes.

Whatever cooling mode is selected, a thermal cutout shuts down power to the LEDs if the fixture temperature exceeds safe limits. If this occurs, you must reset the fixture via the control menus or via DMX, or cycle power to the fixture off and on again.

If a thermal shutdown occurs, you are pushing the fixture to its limits. Clean the fixture, particularly the air vents, and check that there is sufficient airflow around the fixture. Consider increasing ventilation, reducing the ambient temperature, or switching to **FULL** mode. Contact Martin for service if a thermal shutdown persists.

### Dimming

**DIMMER CURVE** provides four dimming options (see Figure 3):

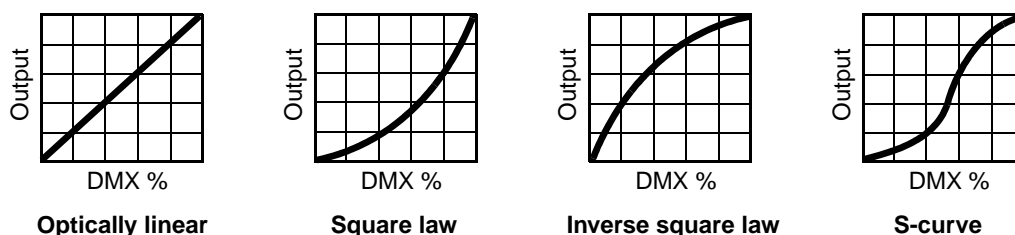

Figure 3: Dimming curve options

- **LINEAR** – the increase in light intensity appears to be linear as DMX value is increased.
- **SQUARE LAW** – light intensity control is finer at low levels and coarser at high levels.
- **INVERSE SQUARE LAW** – light intensity control is coarser at low levels and finer at high levels.
- **S-CURVE** – light intensity control is finer at low levels and high levels and coarser at medium levels.

Whichever **DIMMER CURVE** option you select, you can choose between **FAST** or **SMOOTH** dimming settings:

- **FAST** is the default setting. It gives a virtually instantaneous reaction when you dim from one intensity to another, but dimming slowly from one intensity to another may appear slightly uneven.
- The **SMOOTH** setting gives smoother dimming during slow changes in intensity, but it limits the speed of dimming changes slightly. This makes it ideal for slow, smooth dimming, but a short time-lag may be noticeable if you try to dim quickly from one intensity to another.

## Restoring factory default settings

The MAC 101 factory default settings can be restored by applying a **FACTORY DEFAULT → LOAD** command.

# Operation and effects



**Warning!** Read “Safety Information” starting on page 3 before installing, powering, operating or servicing the MAC 101.

This section describes only DMX control features that require particular explanation. See “DMX protocols” on page 22 for a full list of the DMX channels and values required to control the different effects.

## Pan and tilt

The MAC 101’s moving head can be panned through 540° and tilted through 240°. The speed of pan/tilt movement can be adjusted via the control panel.

All DMX modes offer fine control of pan and tilt. In each case, the main control channel sets the first 8 bits (the most significant byte or MSB), and the fine channel sets the second 8 bits (the least significant byte or LSB) of the 16-bit control byte. In other words, the fine channel works within the position set by the main channel.

## Shutter effect

The electronic ‘shutter’ effect provides instant open and blackout, variable speed regular and random strobe and opening/closing pulse effects as well as burst and sinewave effects.

## Dimming

Overall intensity can be adjusted 0 - 100% using electronic dimming. See “Dimming” on page 14.

## Controlling color (standard MAC 101 RGB only)

### Color wheel effect

The electronic ‘color wheel’ effect gives the convenience and feel of a mechanical color wheel and lets you snap between 33 different full LEE-referenced colors. You can also scroll continuously forwards or backwards through the colors or display random colors at variable speed.

The color wheel effect is available in all DMX modes.

The approximate RGB equivalents of the ‘color wheel’ colors are given in “LEE colors and RGB equivalents” on page 26.

### Color wheel priority

Even if the fixture is set to **RAW** or **RGB** mode, the color wheel effect channel still has priority over the RGB channels. To use the RGB channels, you must set the color wheel effect channel to a DMX value from 000 - 009. If you move the color wheel channel to a DMX value above 009 at any point, the color wheel effect takes over and overrides RGB control.

### RGB color mixing

RGB color mixing is available in raw or calibrated modes:

- Raw RGB mode (**RAW**) is uncalibrated and allows all LEDs to be operated to their absolute maximum output regardless of color calibration issues.
- Calibrated RGB mode (**RGB**) gives slightly reduced LED power but sets LEDs to their factory calibration output power to give the best-matched color and white output across multiple fixtures.

### CTC (Color Temperature Control)

If the fixture is set to **RAW** or **RGB** mode, setting the CTC channel (12) to a DMX value greater than 019 will adjust the fixture’s overall color temperature, i.e. the color that has been set using the color wheel channel or the RGB channels. Note that the more saturated the color, the less it will be affected by adjustments in color temperature. The biggest CTC variation is available when displaying white.

Overall color temperature can be varied from 10 000 - 2500 K. The default color temperature is 5 600 K.



## **Controlling color temperature (MAC 101 CT only)**

### **Warm and cold white mixing**

Warm and cold white mixing is uncalibrated and allows warm and cold white LEDs to be operated on separate DMX channels to their absolute maximum output regardless of white color temperature calibration issues.

### **Color temperature control**

The color temperature control channel is calibrated. It gives slightly reduced LED power but sets LEDs to their factory calibration output power to give the best-matched white color temperature at identical DMX values across multiple fixtures.

## **Controlling warm or cold white (MAC 101 WRM and CLD only)**

Fixture intensity in the MAC 101 WRM and CLD models can be controlled by DMX.

# Service and maintenance



**Warning! Read “Safety Information” on page 3 before servicing the MAC 101.**

**Warning! Disconnect the fixture from AC mains power and allow to cool for at least 10 minutes before handling. Do not view the light output from less than 8.3 meters (27 ft. 3 inches) without shade 4-5 welding goggles. Be prepared for the fixture to light suddenly if connected to power.**



**Warning! Refer any service operation not described in this user manual to a qualified service technician.**



**Important! Excessive dust, smoke fluid, and particle buildup degrades performance, causes overheating and will damage the fixture. Damage caused by inadequate cleaning or maintenance is not covered by the product warranty.**



The user will need to clean the MAC 101 periodically, and it is also possible for the user to update the firmware and install the optional diffuser accessory available from Martin. All other service operations on the MAC 101 must be carried out by Martin Professional or its approved service agents.

Installation, on-site service and maintenance can be provided worldwide by the Martin Professional Global Service organization and its approved agents, giving owners access to Martin's expertise and product knowledge in a partnership that will ensure the highest level of performance throughout the product's lifetime. Please contact your Martin supplier for details.

It is Martin policy to apply the strictest possible calibration procedures and use the best quality materials available to ensure optimum performance and the longest possible component lifetimes. However, LEDs are subject to wear and tear over the life of the product, resulting in gradual changes in color and overall brightness over many thousands of hours of use. The extent of wear and tear depends heavily on operating conditions and environment, so it is impossible to specify precisely whether and to what extent LED performance will be affected. However, you may eventually need to ask Martin Professional to replace LEDs if their characteristics are affected by wear and tear after an extended period of use and if you require fixtures to perform within very precise optical and color parameters.

The manufacturer's LED lifetime data is based on performance under the manufacturer's test conditions. As with all LEDs, the gradual reduction in luminous output will be accelerated when LEDs are used in a fixture, where conditions are much tougher than in manufacturer's testing. To maximize LED lifetimes, keep the ambient temperature as low as possible and drive the LEDs no harder and for no longer than necessary.

## Cleaning

Cleaning schedules for lighting fixtures vary greatly depending on the operating environment. It is therefore impossible to specify precise cleaning intervals for the MAC 101. Environmental factors that may result in a need for frequent cleaning include:

- Use of smoke or fog machines.
- High airflow rates (near air conditioning vents, for example).
- Presence of cigarette smoke.
- Airborne dust (from stage effects, building structures and fittings or the natural environment at outdoor events, for example).

If one or more of these factors is present, inspect fixtures within their first 100 hours of operation to see whether cleaning is necessary. Check again at frequent intervals. This procedure will allow you to assess cleaning requirements in your particular situation. If in doubt, consult your Martin dealer about a suitable maintenance schedule.

Use gentle pressure only when cleaning, and work in a clean, well-lit area. Do not use any product that contains solvents or abrasives, as these can cause surface damage.

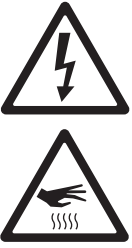

**Warning! Disconnect from power and allow to cool before cleaning.**

To clean the fixture:

1. Disconnect the fixture from power and allow it to cool for at least 10 minutes.
2. Vacuum or gently blow away dust and loose particles from the outside of the fixture and the air vents at the back and sides of the head and in the base with low-pressure compressed air.
3. Remove the central screw from the grill on the front of the head, remove the grill and clean the LED lenses by wiping gently with a soft, clean lint-free cloth moistened with a weak detergent solution. Do not rub the surface hard: lift particles off with a soft repeated press. Dry with a soft, clean, lint-free cloth or low-pressure compressed air. Remove stuck particles with an unscented tissue or cotton swab moistened with glass cleaner or distilled water.
4. Reinstall the grill over the LED lenses in the front of the head and secure it with its screw.
5. See Figure 4. Remove the grill from the fan on the back of the head by inserting a small flat-bladed screwdriver between the head and the arrow on the grill and levering the grill out of the head. Use cotton swabs (cotton buds) and a vacuum cleaner to clean the grill and the blades of the head fan, then clip the grill back into place.
6. Check that the fixture is dry before reapplying power.

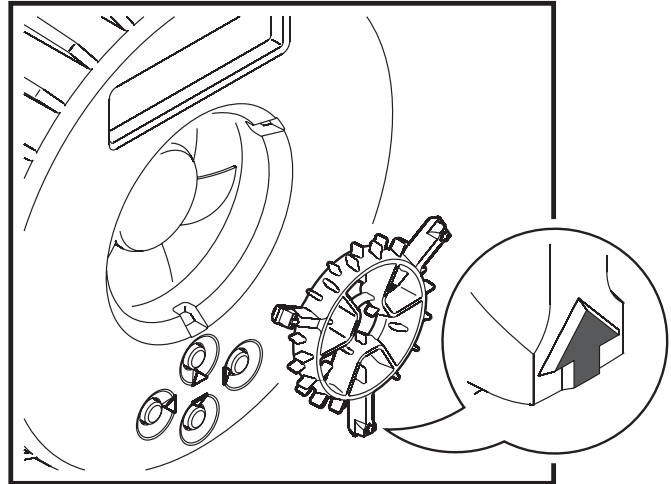

**Figure 4: Head fan grill removal**

## Control menu service utilities

### Functions test

The **TEST** feature provides four test routines, allowing testing of pan/tilt, LEDs and display separately or together without a controller.

### Pan and tilt calibration

Pan and tilt on the MAC 101 are calibrated at the factory so that movement is identical in multiple fixtures. Adjustment should not be necessary initially, but over a period of use fixtures may gradually lose calibration. If re-calibration is necessary:

1. Pan calibration is easiest when multiple fixtures are stacked vertically. To calibrate, set tilt positions for easy one-over-the-other comparison and set each fixture to the same pan DMX value. Select one fixture to be the reference fixture. On that fixture, select **SERVICE** → **CALIBRATION** → **PAN OFFSET** and press **▶**. Wait for the fixture to move to its pan calibration position.
2. On each of the other fixtures, select **SERVICE** → **CALIBRATION** → **PAN OFFSET** and press **▶**. Wait for the head to move to the pan calibration position, then adjust the pan offset using the **▲** and **▼** buttons as necessary to align the beam with the reference beam. Press **▶** to save the setting, then **◀** to exit.
3. Tilt calibration is easiest when multiple fixtures are arranged side-by-side horizontally. To calibrate, set pan positions for easy side-by-side comparison. Select one fixture to be the reference fixture. On that fixture, select **SERVICE** → **CALIBRATION** → **TILT OFFSET** and press **▶**. Wait for the fixture to move to its tilt calibration position.
4. On each of the other fixtures, select **SERVICE** → **CALIBRATION** → **TILT OFFSET** and press **▶**. Wait for the head to move to the tilt calibration position, then adjust the tilt offset using the **▲** and **▼** buttons as necessary to align the beam with the reference beam. Press **▶** to save the setting, then **◀** to exit.

## Software upload

The MAC 101 is loaded with both software (that can be installed and updated by the user) and firmware (that is internal and accessible to Martin Service and its authorized partners only). Software updates are available from the Martin website and can be installed with a PC and Martin USB Duo DMX Interface box that can upload software to one fixture at a time.

The following are required in order to install software:

- The latest version of the MAC 101 software, available for download free of charge from the Product Support area of the Martin website at <http://www.martin.com>
- A PC running Windows 98/2000/XP
- The Windows-based Martin Uploader application available for download free of charge from the Downloads Area of the Martin website at <http://www.martin.com>
- Martin USB Duo DMX Interface Box with its supplied cables.

### Installing software: normal method

1. Connect the Uploader hardware to a MAC 101 fixture's data input connector.
2. Upload the fixture software as described in the uploader's help file or user documentation.
3. Disconnect the Uploader hardware and reconnect the fixture to the DMX link.
4. Cycle power off and on. Check that the fixture resets correctly. If an error message appears in the display, cycle power off and on again and check that the fixture now resets correctly.

## Fixture readouts

### DMX input signal

The **DMX LIVE** menu lets you view the DMX values received on each channel. If the fixture does not behave as expected, reading the DMX values can help you troubleshoot the problem.

### Fixture status

The MAC 101 gives fixture status readouts in the **INFO** menu:

- Current software/firmware version information.
- Temperature readouts from the power supply unit in the base and LED PCB in the head. In each case, you can view the current temperature and the maximum temperature reached since the readout was last reset. The maximum temperatures can be reset individually. The **TOTAL** temperature counters are not resettable.
- Power on hours. You can view the number of hours since the resettable counter was last reset or the total number of hours since manufacture. You can also reset the resettable counter to zero.
- The manufacturer's serial number and the fixture's RDM ID number.

### Display messages

If an error occurs, the MAC 101 gives fixture status readouts in the display. See "Display messages" on page 29.

## Lubrication

In general, the MAC 101 does not require lubrication. However, depending on use conditions, the moving parts in the pan and tilt mechanisms may eventually require reapplication of lubricant. Excessive noise during pan/tilt movement is a sign that lubrication may be required. This operation can be carried out by a Martin service partner if necessary.

## Installing optional diffuser filters

A set of eight medium-angle diffuser filters can be ordered from Martin (P/N 91616018) as an optional accessory for the MAC 101. A diffuser filter softens the output from the LEDs and provides a wider beam angle.

To install a diffuser filter:

1. Shut down power to the fixture and allow it to cool for at least 10 minutes.
2. Release the Torx screw in the center of the spill ring and lift the spill ring off. Keep the screw for use during reassembly and keep the spill ring for possible future use.
3. Place the diffuser filter over the lens plate so that the cutouts in the diffuser locate over the tabs around the edge of the lens plate (see Figure 5).
4. Do not reinstall the spill ring, as this will limit the beam angle with the diffuser filter installed. Reuse the screw from step 2. in the center of the diffuser filter to secure it.

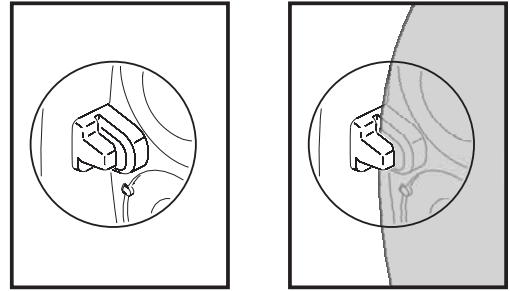

Figure 5: Diffuser filter locating tabs

If you remove the diffuser filter in the future, we recommend that you reinstall the original spill ring. See Figure 6. Line up the two small arrowheads (arrowed) molded into the lens plate and spill ring and press the spill ring onto the lens plate so that the locating tabs in the lens plate engage in the cutouts in the spill ring.

Fasten the spill ring to the head reusing the Torx screw in the center of the spill ring.

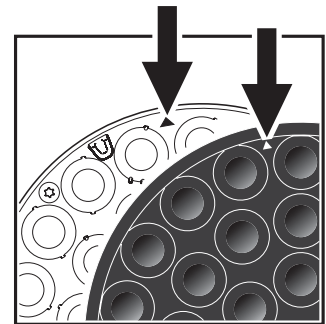

Figure 6: Alignment arrowheads

## Installing an optional top hat

Top hats (P/N 91611358) can be ordered from Martin as optional accessories for the MAC 101. The Martin top hat reduces glare and spill from the MAC 101 and installs in seconds.

**Important! The top hat has a lightweight design. Avoid shocks and rough handling.**

To install a top hat:

1. Enable the **TOP HAT** setting in the **PERSONALITY** menu. This will limit tilt by a few degrees each side to avoid collisions between the top hat and the MAC 101's base at maximum tilt.
2. See Figure 7. Line up the top hat so that the pairs of retaining clips pass closely on either side of the tilt pivots in the sides of the head.
3. Push the top hat onto the head and engage all four clips firmly in the cooling vents in the back of the head.

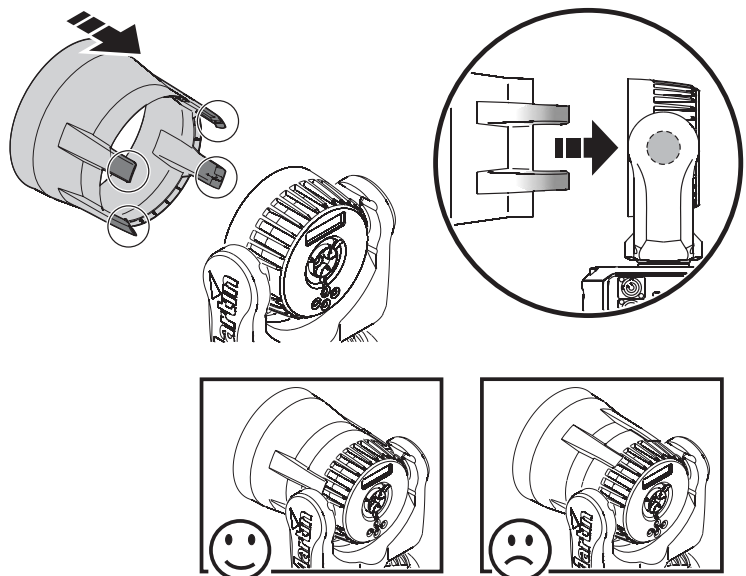

Figure 7: Installing a top hat

# DMX protocols

## Standard MAC 101 RGB DMX protocol

Raw, RGB	Basic	DMX Value	Percent	Function
<b>1</b>	<b>1</b>	0 - 19	0 - 7	<b>Electronic shutter effect</b>
		20 - 49	8 - 19	Shutter closed
		50 - 64	20 - 25	Shutter open
		65 - 69	26 - 27	Strobe 1 (fast → slow)
		70 - 84	28 - 33	Shutter open
		85 - 89	34 - 35	Strobe 2: opening pulse (fast → slow)
		90 - 104	36 - 41	Shutter open
		105 - 109	42 - 43	Strobe 3: closing pulse (fast → slow)
		110 - 124	44 - 49	Shutter open
		125 - 129	50 - 51	Strobe 4: random strobe (fast → slow)
		130 - 144	52 - 57	Shutter open
		145 - 149	58 - 59	Strobe 5: random opening pulse (fast → slow)
		150 - 164	60 - 65	Shutter open
		165 - 169	66 - 67	Strobe 6: random closing pulse (fast → slow)
		170 - 184	68 - 73	Shutter open
		185 - 189	74 - 75	Strobe 7: burst pulse (fast → slow)
		190 - 204	76 - 81	Shutter open
		205 - 209	82 - 83	Strobe 8: random burst pulse (fast → slow)
		210 - 224	84 - 89	Shutter open
		225 - 229	90 - 91	Strobe 9: sine wave (fast → slow)
230 - 244	92 - 97	Shutter open		
245 - 255	98 - 100	Strobe 10: burst (fast → slow)		
				Shutter open
<b>2</b>	<b>2</b>	0 - 255	0 - 100	<b>Dimmer</b> 0 → 100% intensity
<b>3</b>	<b>3</b>	0 - 255	0 - 100	<b>Pan</b> Pan 0 - 430°
<b>4</b>	<b>4</b>	0 - 255	0 - 100	<b>Pan fine</b> Pan fine (Least Significant Byte)
<b>5</b>	<b>5</b>	0 - 255	0 - 100	<b>Tilt</b> Tilt 0 - 300°
<b>6</b>	<b>6</b>	0 - 255	0 - 100	<b>Tilt fine</b> Tilt fine (Least Significant Byte)
<b>7</b>	<b>7</b>	0 - 9	0 - 1	<b>Fixture control settings</b>
		10 - 14	2 - 3	<i>No function</i>
		15 - 39	4 - 13	Reset entire fixture <sup>1</sup>
		40 - 44	14 - 15	<i>No function</i>
		45 - 49	16 - 17	PTSP = NORM <sup>2</sup>
		50 - 54	18 - 19	PTSP = FAST <sup>2</sup>
		55 - 59	20 - 21	PTSP = SLOW <sup>2</sup>
		60 - 64	22 - 23	<i>No function</i>
		65 - 69	24 - 25	Fan mode FULL <sup>2</sup>
		70 - 74	26 - 27	<i>No function</i>
		75 - 89	28 - 33	Fan mode REGULATED <sup>2</sup>
		90 - 94	34 - 35	<i>No function</i>
		95 - 99	36 - 37	RGB control mode (calibrated RGB) <sup>3</sup>
		100 - 104	38 - 40	<i>No function</i>
		105 - 109	41 - 42	RAW control mode (uncalibrated RGB) <sup>3</sup>
		110 - 114	43 - 44	<i>No function</i>
		115 - 119	45 - 46	Fast dimming, speed of changes unrestricted <sup>2</sup>
		120 - 124	47 - 48	<i>No function</i>
		125 - 249	49 - 97	Smooth dimming, speed of changes restricted slightly <sup>2</sup>
		250 - 255	98 - 100	<i>No function</i>
				Illuminate display
				<sup>1</sup> If DMX Reset is disabled in the menu, a reset command can only be executed if channel 2 is set to 232 and channel 1 is set to zero. These values need to be held for 5 seconds before feature is activated. Values must be "snapped to" to function.
				<sup>2</sup> Menu override: setting unaffected by power off/on.
				<sup>3</sup> Value must be held for 3 seconds to activate. Setting unaffected by power off/on.

Table 2: MAC 101 DMX Protocol

Raw, RGB	Basic	DMX Value	Percent	Function
<b>8</b>	<b>8</b>	0 - 9	0 - 1	<b>Color wheel effect</b> Open. RGB color mixing enabled if the fixture is set to <b>RAW</b> or <b>RGB</b> modes
		10 - 14	2 - 3	LEE 790 - Moroccan pink
		15 - 19	4 - 5	LEE 157 - Pink
		20 - 24	6 - 7	LEE 332 - Special rose pink
		25 - 29	8 - 9	LEE 328 - Follies pink
		30 - 34	10 - 11	LEE 345 - Fuchsia pink
		35 - 39	12 - 13	LEE 194 - Surprise pink
		40 - 44	14 - 15	LEE 181 - Congo Blue
		45 - 49	16 - 17	LEE 071 - Tokyo Blue
		50 - 54	18 - 19	LEE 120 - Deep Blue
		55 - 59	20 - 21	LEE 079 - Just Blue
		60 - 64	22 - 23	LEE 132 - Medium Blue
		65 - 69	24 - 25	LEE 200 - Double CT Blue
		70 - 74	26 - 27	LEE 161 - Slate Blue
		75 - 79	28 - 29	LEE 201 - Full CT Blue
		80 - 84	30 - 31	LEE 202 - Half CT Blue
		85 - 89	32 - 33	LEE 117 - Steel Blue
		90 - 94	34 - 35	LEE 353 - Lighter Blue
		95 - 99	36 - 37	LEE 118 - Light Blue
		100 - 104	38 - 39	LEE 116 - Medium Blue Green
		105 - 109	40 - 41	LEE 124 - Dark Green
		110 - 114	42 - 43	LEE 139 - Primary Green
		115 - 119	44 - 45	LEE 089 - Moss Green
		120 - 124	46 - 47	LEE 122 - Fern Green
		125 - 129	48 - 49	LEE 738 - JAS Green
		130 - 134	50 - 51	LEE 088 - Lime Green
		135 - 139	52 - 53	LEE 100 - Spring Yellow
		140 - 144	54 - 55	LEE 104 - Deep Amber
		145 - 149	56 - 57	LEE 179 - Chrome Orange
		150 - 154	58 - 59	LEE 105 - Orange
155 - 159	60 - 61	LEE 021 - Gold Amber		
160 - 164	62 - 63	LEE 778 - Millennium Gold		
165 - 169	64 - 65	LEE 135 - Deep Golden Amber		
170 - 174	66 - 67	LEE 164 - Flame Red		
175 - 179	68 - 69	Open		
		180 - 201	70 - 78	<b>Color wheel rotation effect</b> Clockwise, fast → slow
		202 - 207	79 - 80	Stop (this will stop wherever the color is at the time)
		208 - 229	81 - 89	Counter-clockwise, slow → fast
		230 - 234	90 - 91	Open
		235 - 239	92 - 93	<b>Random color</b> Fast
		240 - 244	94 - 95	Medium
		245 - 249	96 - 97	Slow
		250 - 255	98 - 100	Open
<b>9</b>		0 - 255	0 - 100	<b>Red</b> Red 0 → 100%
<b>10</b>		0 - 255	0 - 100	<b>Green</b> Green 0 → 100%
<b>11</b>		0 - 255	0 - 100	<b>Blue</b> Blue 0 → 100%
<b>12</b>		0 - 19	0 - 7	<b>Color Temperature Control</b> No Function
		20 - 255	8 - 100	CTC 10 000K → 2 500K

**Table 2: MAC 101 DMX Protocol**

Note: DMX values labeled "No function" will have no effect - the last functional value will be used.

In **RAW** mode, RGB output is uncalibrated. In **RGB** mode, output is calibrated

# MAC 101 CT DMX protocol

DMX Channel	DMX Value	Percent	Function
<b>1</b>	0 - 19	0 - 7	<b>Electronic shutter effect</b> Shutter closed
	20 - 49	8 - 19	Shutter open
	50 - 64	20 - 25	Strobe 1 (fast → slow)
	65 - 69	26 - 27	Shutter open
	70 - 84	28 - 33	Strobe 2: opening pulse (fast → slow)
	85 - 89	34 - 35	Shutter open
	90 - 104	36 - 41	Strobe 3: closing pulse (fast → slow)
	105 - 109	42 - 43	Shutter open
	110 - 124	44 - 49	Strobe 4: random strobe (fast → slow)
	125 - 129	50 - 51	Shutter open
	130 - 144	52 - 57	Strobe 5: random opening pulse (fast → slow)
	145 - 149	58 - 59	Shutter open
	150 - 164	60 - 65	Strobe 6: random closing pulse (fast → slow)
	165 - 169	66 - 67	Shutter open
	170 - 184	68 - 73	Strobe 7: burst pulse (fast → slow)
	185 - 189	74 - 75	Shutter open
	190 - 204	76 - 81	Strobe 8: random burst pulse (fast → slow)
	205 - 209	82 - 83	Shutter open
	210 - 224	84 - 89	Strobe 9: sine wave (fast → slow)
	225 - 229	90 - 91	Shutter open
230 - 244	92 - 97	Strobe 10: burst (fast → slow)	
245 - 255	98 - 100	Shutter open	
<b>2</b>	0 - 255	0 - 100	<b>Dimmer</b> 0 → 100% intensity
<b>3</b>	0 - 255	0 - 100	<b>Pan</b> Pan 0 - 430°
<b>4</b>	0 - 255	0 - 100	<b>Pan fine</b> Pan fine (Least Significant Byte)
<b>5</b>	0 - 255	0 - 100	<b>Tilt</b> Tilt 0 - 300°
<b>6</b>	0 - 255	0 - 100	<b>Tilt fine</b> Tilt fine (Least Significant Byte)
<b>7</b>	0 - 9	0 - 1	<b>Fixture control settings</b> <i>No function</i>
	10 - 14	2 - 3	Reset entire fixture <sup>1</sup>
	15 - 39	4 - 13	<i>No function</i>
	40 - 44	14 - 15	PTSP = NORM <sup>2</sup>
	45 - 49	16 - 17	PTSP = FAST <sup>2</sup>
	50 - 54	18 - 19	PTSP = SLOW <sup>2</sup>
	55 - 59	20 - 21	<i>No function</i>
	60 - 64	22 - 23	Fan mode FULL <sup>2</sup>
	65 - 69	24 - 25	<i>No function</i>
	70 - 74	26 - 27	Fan mode REGULATED <sup>2</sup>
	75 - 109	28 - 42	<i>No function</i>
	110 - 114	43 - 44	Fast dimming, speed of changes unrestricted <sup>2</sup>
	115 - 119	45 - 46	<i>No function</i>
	120 - 124	47 - 48	Smooth dimming, speed of changes restricted slightly <sup>2</sup>
	125 - 249	49 - 97	<i>No function</i>
	250 - 255	98 - 100	Illuminate display
			<sup>1</sup> If DMX Reset is disabled in the menu, a reset command can only be executed if channel 2 is set to 232 and channel 1 is set to zero. These values need to be held for 5 seconds before feature is activated. Values must be "snapped to" to function.
			<sup>2</sup> Menu override: setting unaffected by power off/on.
<b>8</b>	0 - 255	0 - 100	<b>Warm LEDs</b> 0 → 100% intensity
<b>9</b>	0 - 255	0 - 100	<b>Cold LEDs</b> 0 → 100% intensity
<b>10</b>	0 - 19	0 - 7	<b>Color Temperature Control</b> No Function
	20 - 255	8 - 100	Color temperature, calibrated, 6200 → 2800 K

Table 3: MAC 101 CT DMX Protocol



# MAC 101 CLD and MAC 101 WRM DMX protocol

DMX Channel	DMX Value	Percent	Function
<b>1</b>	0 - 19	0 - 7	<b>Electronic shutter effect</b> Shutter closed
	20 - 49	8 - 19	Shutter open
	50 - 64	20 - 25	Strobe 1 (fast → slow)
	65 - 69	26 - 27	Shutter open
	70 - 84	28 - 33	Strobe 2: opening pulse (fast → slow)
	85 - 89	34 - 35	Shutter open
	90 - 104	36 - 41	Strobe 3: closing pulse (fast → slow)
	105 - 109	42 - 43	Shutter open
	110 - 124	44 - 49	Strobe 4: random strobe (fast → slow)
	125 - 129	50 - 51	Shutter open
	130 - 144	52 - 57	Strobe 5: random opening pulse (fast → slow)
	145 - 149	58 - 59	Shutter open
	150 - 164	60 - 65	Strobe 6: random closing pulse (fast → slow)
	165 - 169	66 - 67	Shutter open
	170 - 184	68 - 73	Strobe 7: burst pulse (fast → slow)
	185 - 189	74 - 75	Shutter open
	190 - 204	76 - 81	Strobe 8: random burst pulse (fast → slow)
	205 - 209	82 - 83	Shutter open
	210 - 224	84 - 89	Strobe 9: sine wave (fast → slow)
	225 - 229	90 - 91	Shutter open
230 - 244	92 - 97	Strobe 10: burst (fast → slow)	
245 - 255	98 - 100	Shutter open	
<b>2</b>	0 - 255	0 - 100	<b>Dimmer</b> 0 → 100% intensity
<b>3</b>	0 - 255	0 - 100	<b>Pan</b> Pan 0 - 430°
<b>4</b>	0 - 255	0 - 100	<b>Pan fine</b> Pan fine (Least Significant Byte)
<b>5</b>	0 - 255	0 - 100	<b>Tilt</b> Tilt 0 - 300°
<b>6</b>	0 - 255	0 - 100	<b>Tilt fine</b> Tilt fine (Least Significant Byte)
<b>7</b>	0 - 9	0 - 1	<b>Fixture control settings</b> <i>No function</i>
	10 - 14	2 - 3	Reset entire fixture <sup>1</sup>
	15 - 39	4 - 13	<i>No function</i>
	40 - 44	14 - 15	PTSP = NORM <sup>2</sup>
	45 - 49	16 - 17	PTSP = FAST <sup>2</sup>
	50 - 54	18 - 19	PTSP = SLOW <sup>2</sup>
	55 - 59	20 - 21	<i>No function</i>
	60 - 64	22 - 23	Fan mode FULL <sup>2</sup>
	65 - 69	24 - 25	<i>No function</i>
	70 - 74	26 - 27	Fan mode REGULATED <sup>2</sup>
	75 - 109	28 - 42	<i>No function</i>
	110 - 114	43 - 44	Fast dimming, speed of changes unrestricted <sup>2</sup>
	115 - 119	45 - 46	<i>No function</i>
	120 - 124	47 - 48	Smooth dimming, speed of changes restricted slightly <sup>2</sup>
	125 - 249	49 - 97	<i>No function</i>
	250 - 255	98 - 100	Illuminate display
			<sup>2</sup> Menu override: setting unaffected by power off/on.

Table 4: MAC 101 CLD and WRM DMX Protocol

# LEE colors and RGB equivalents

The table below gives approximate RGB equivalents for the LEE colors available in the standard MAC 101's color wheel effect (DMX channel 9).

Lee no.	Name	DMX Integer		
		Red	Green	Blue
790	Moroccan Pink	255	235	052
157	Pink	214	134	048
332	Special rose Pink	255	000	044
328	Follies Pink	255	059	113
345	Fuchsia Pink	255	138	219
194	Surprise Pink	226	175	226
181	Congo Blue	040	001	255
071	Tokyo Blue	000	000	255
120	Deep Blue	000	078	255
079	Just Blue	000	199	255
132	Medium Blue	000	255	234
200	Double CT Blue	149	246	255
161	State Blue	137	255	227
201	Full CT Blue	213	220	222
202	Half CT Blue	219	232	175
117	Steel Blue	205	255	199
353	Lighter Blue	115	255	165
118	Light Blue	006	255	143
116	Medium Blue Green	000	255	94
124	Dark Green	029	255	000
139	Primary Green	032	223	000
089	Moss Green	075	255	000
122	Fern Green	080	232	000
738	JAS Green	108	226	000
088	Lime Green	145	194	000
100	Spring Yellow	210	255	000
104	Deep Amber	225	232	000
179	Chrome Orange	023	215	000
105	Orange	247	214	000
021	Gold Amber	255	163	000
778	Millennium Gold	255	152	000
135	Deep Golden Amber	255	108	000
164	Flame Red	255	080	000

# Onboard control menus

Menu	Item	Options	Notes (Default settings in bold print)
<b>DMX ADDRESS</b>		<b>1 – XXX</b>	DMX address (default address = 1). The DMX address range is limited so that the fixture will always have enough DMX channels in the 512 available.
<b>CONT MODE</b> <sup>1</sup>	<b>RAW</b>		<b>RGB uncalibrated DMX control mode</b>
	<b>RGB</b>		RGB calibrated DMX control mode
	<b>BASIC</b>		Basic DMX control mode
<b>PERSONALITY</b>	<b>P/T SETTING</b>	<b>P/T SPEED</b>	Pan and tilt speed <b>normal</b> / fast / slow
		<b>SWAP</b>	Swap pan and tilt (pan commands move tilt and vice versa) - <b>off</b> / on
		<b>PAN INVERT</b>	Pan inversion (reverse direction pan control) - <b>off</b> / on
		<b>TILT INVERT</b>	Tilt inversion (reverse direction tilt control) - <b>off</b> / on
	<b>FANS</b>	<b>REGULATED</b>	<b>Cooling fan speed thermostatically regulated</b>
		<b>FULL</b>	Max. cooling fan speed
	<b>DIMMER CURVE</b>	<b>LINEAR</b>	Linear dimming curve
		<b>SQUARE LAW</b>	<b>Square law dimming curve</b>
		<b>INV SQUARE LAW</b>	Inverse square law dimming curve
		<b>S-CURVE</b>	S-curve dimming curve
	<b>DIMMER SPEED</b>	<b>FAST</b>	<b>Fast dimming with unrestricted speed</b>
		<b>SMOOTH</b>	Smooth dimming with restricted speed
	<b>DMX RESET</b>	<b>OFF</b>	Disable reset via DMX
		<b>ON</b>	<b>Enable reset via DMX</b>
	<b>DISPLAY</b>	<b>ON</b>	Display is always on
		<b>2MN</b>	<b>Display switches off and goes into Sleep mode if the controls have not been pressed for 2 minutes.</b>
		<b>5MN</b>	Display switches off and goes into Sleep mode if the controls have not been pressed for 5 minutes
		<b>10MN</b>	Display switches off and goes into Sleep mode if the controls have not been pressed for 10 minutes
	<b>DISPLAY INTENSITY</b>	<b>10-100</b>	Display intensity. Default= <b>100</b>
	<b>ERROR MODE</b>	<b>NORMAL</b>	<b>Display errors at 100% intensity (regardless of DISPLAY INTENSITY setting) and illuminate the service light</b>
		<b>SILENT</b>	Silent error mode. The error message does not appear in the display, but the service lamp is illuminated
	<b>TOP HAT</b>	<b>DISABLE</b>	<b>No tilt limitation</b>
<b>ENABLE</b>		Tilt limited by a few degrees to avoid collision between top hat and base at maximum tilt – enable this setting before installing a top hat	
<b>FACTORY SETTING</b>	<b>FACTORY DEFAULT</b>	<b>LOAD</b>	Return all settings (except calibrations) to factory defaults <i>NB: can take up to 2 minutes to complete!</i>

Table 5: Control menu

Menu	Item	Options	Notes (Default settings in bold print)
INFO	<b>VERSION</b>		CPU firmware version
	<b>POWER ON HOURS</b>	<b>RESETTABLE</b>	Hours of operation since counter reset
		<b>TOTAL</b>	Total hours of operation since manufacture
		<b>CLEAR RESETTABLE</b>	Reset resettable counter to zero
	<b>MAIN PCB TEMP</b>	<b>CURRENT</b>	Display current main PCB temperature
		<b>SINCE RESET</b>	Display highest main PCB temperature since last reset
		<b>TOTAL</b>	Display highest main PCB temperature since manufacture
	<b>PIXEL TEMP</b>	<b>CURRENT</b>	Display current average LED temperature
		<b>SINCE RESET</b>	Display highest average LED temperature since last reset
		<b>TOTAL</b>	Display highest average LED temperature since manufacture
<b>SERIAL NUMBERS</b>	<b>RDM</b>	Display fixture's RDM ID	
	<b>FIXT SERIAL NUMBER</b>	Display fixture's serial number	
TEST	<b>TEST ALL</b>		Test LEDs and pan/tilt movement
	<b>TEST LED</b>		Test LEDs only
	<b>TEST PAN &amp; TILT</b>		Test pan/tilt movement only
	<b>TEST DISPLAY</b>		Test all segments in onboard display panel
DMX LIVE	<b>RATE</b>	<b>xx Hz</b>	DMX transmission speed, live, in packets per second
	<b>QUALITY</b>	<b>0 - 100%</b>	Percentage of packets received with errors, live
	<b>START CODE</b>	<b>0 - 255</b>	Decimal value of the DMX start code, live
	<b>SHUTTER</b>	<b>0 - 255</b>	DMX value received on that channel
	<b>DIMMER</b>	<b>0 - 255</b>	DMX value received on that channel
	<b>PAN</b>	<b>0 - 255</b>	DMX value received on that channel
	<b>PAN FINE</b>	<b>0 - 255</b>	DMX value received on that channel
	<b>TILT</b>	<b>0 - 255</b>	DMX value received on that channel
	<b>TILT FINE</b>	<b>0 - 255</b>	DMX value received on that channel
	<b>CONTROL</b>	<b>0 - 255</b>	DMX value received on that channel
	<b>COLOR WHEEL<sup>1</sup></b>	<b>0 - 255</b>	DMX value received on that channel
	<b>RED<sup>2</sup></b>	<b>0 - 255</b>	DMX value received on that channel
	<b>GREEN<sup>2</sup></b>	<b>0 - 255</b>	DMX value received on that channel
	<b>BLUE<sup>2</sup></b>	<b>0 - 255</b>	DMX value received on that channel
	<b>CTC<sup>2</sup></b>	<b>0 - 255</b>	DMX value received on that channel
	<b>WARM WHITE<sup>3</sup></b>	<b>0 - 255</b>	DMX value received on that channel
<b>COLD WHITE<sup>3</sup></b>	<b>0 - 255</b>	DMX value received on that channel	
<b>CTC<sup>3</sup></b>	<b>0 - 255</b>	DMX value received on that channel	
SERVICE	<b>P/T FEEDBACK</b>	<b>ON</b>	<b>Enable pan/tilt position feedback/correction system</b>
		<b>OFF</b>	Disable pan/tilt feedback for servicing (this setting is not saved when fixture is reset)
	<b>CALIBRATION</b>	<b>PAN OFFSET</b>	Pan calibration
		<b>TILT OFFSET</b>	Tilt calibration

Table 5: Control menu

<sup>1</sup> Standard MAC 101 only, shown in menu in all DMX control modes.

<sup>2</sup> Standard MAC 101 only, shown in menu when fixture is set to **RAW** or **RGB** DMX control modes

<sup>3</sup> MAC 101 CT only

# Display messages

Message	Appears when...	What to do
<b>RST</b> (Reset)	... the fixture is indexing effects at startup.	Wait for reset to complete.
<b>SRST</b> (Serial reset)	... the fixture has received a reset command.	Wait for reset to complete. Note that you can set <b>PERSONALITY</b> → <b>DMX RESET</b> to <b>OFF</b> to prevent accidental DMX reset commands.
<b>MERR - MEMORY ERROR</b>	...the EEPROM memory cannot be read.	Reset fixture. Contact Martin if problem persists.
<b>HTSE - HEAD TMP SEN ERR</b>	...there is a malfunction in the head temperature sensor circuit.	Contact Martin service for assistance.
<b>LTSE - LAMP TMP SEN ERROR</b>	...there is a malfunction in the LED temperature sensor circuit.	Contact Martin service for assistance.
<b>HTCO - HEAD TMP CUT OFF</b>	...the head temperature sensor measures that head temperature is too high. Power to the LEDs is cut off.	Check that ambient temperature is not too high. Check that the fixture is clean. Check that there is free airflow around the fixture. Contact Martin service for assistance.
<b>LTCO - LAMP TMP CUT OFF</b>	...the LED temperature sensor measures that LED temperature is too high. Power to the LEDs is cut off.	Contact Martin service for assistance.
<b>FBEP - PAN FBACK ERR</b> <b>FBET - TILT FBACK ERR</b>	...there is a malfunction in the optical pan/tilt monitoring circuit (e.g. sensor defective). After a time-out, the effect in question stops in a random position.	Reset fixture. Contact Martin service if problem continues.
<b>PSER - PAN SENSOR ERR</b> <b>TIER - TILT SENSOR ERR</b> <b>DRER - DRIVER CURR ERR</b>	...there is a malfunction in the electrical indexing circuit for pan, tilt or one of the drivers. After a time-out, the fixture will establish a mechanical stop, and continue to work normally.	Reset fixture. Contact Martin service if problem continues.
<b>VOLT - VOLTAGE ERR</b> <b>RAME - RAM ERROR</b>	...there is a voltage or RAM error.	Reset fixture. Contact Martin service if problem continues.
<b>COLD - EFFECTS TOO COLD</b>	...the onboard thermostat measures that the effects are too cold.	Leave fixture powered on to warm it up. Contact Martin service if problem continues or fixture is warm.
<b>FAN - FAN ERROR</b>	...there is a fan or fan driver error.	Check that fan on rear of head is free to rotate freely. Contact Martin service for assistance.
<b>COER - COLOR ERROR</b>	...there is a driver error.	Contact Martin service for assistance.
<b>CCER - COLOR CALIB ERR</b>	...color calibration data is invalid or communication error.	Contact Martin service for assistance.

**Table 6: Display messages**

# Troubleshooting

<b>Problem</b>	<b>Probable cause(s)</b>	<b>Remedy</b>
Fixture is completely dead.	No power to fixture.	Check AC mains power and connections.
	Internal circuit fault.	Have faulty fixture serviced by Martin service technician.
One or more fixtures resets correctly but responds erratically or not at all to the controller.	Fault on data link.	Inspect connections and cables. Correct poor connections. Repair or replace damaged cables.
	Data link not terminated.	Insert termination plug in output connector of the last fixture on the link.
	Incorrect fixture DMX addressing.	Check addressing on fixture and controller. Check fixture is set to correct DMX mode.
	One of the fixtures is defective and is disturbing data transmission on the link.	Unplug XLR in and out connectors and connect them directly together to bypass one fixture at a time until normal operation is regained. Have faulty fixture serviced by Martin service technician.
	XLR pin-out on fixtures does not match (pins 2 and 3 reversed).	Install a phase-reversing cable between the fixtures or swap pins 2 and 3 in the fixture that behaves erratically.
Light output shuts down unexpectedly.	Fixture is too hot.	Clean the fixture, especially air vents. Ensure free airflow around fixture. Check that ambient temperature does not exceed max. permitted level. Switch to FULL cooling mode. If problem persists, contact Martin for advice.

**Table 7: Troubleshooting**

# Specifications

## Physical

Length	.241 mm (9.5 in.) across yoke
Width	.241 mm (9.5 in.) across yoke
Height	.304 mm (12.0 in.)
Weight	3.7 kg (8.2 lbs.)

## Dynamic Effects

### MAC 101 RGB

Electronic color wheel effect	33 LEE-referenced colors plus white, color wheel rotation effect
Color mixing	RGB
Red	0 - 100%
Green	0 - 100%
Blue	0 - 100%
Color temperature control	Variable 10 000 - 2500 K

### MAC 101 CT

Color temperature control	Variable 2800 - 6200 K
---------------------------	------------------------

### All models

Shutter effect	Electronic, with pulse and random effects
Electronic dimming	0 - 100%, four dimming curve options
Pan	540°
Tilt	240°
Pan/tilt speed	Adjustable

## Optics and Photometric Data

### MAC 101 RGB

Light source	12 red, 12 green and 12 blue Cree XP-E high power emitters
Total luminous output	2300 lm

### MAC 101 CT

Light source	12 cold white and 24 warm white Cree XP-E high power emitters
Total luminous output	4000 lm

### MAC 101 WRM

Light source	36 warm white (2800 K) Cree XP-E high power emitters
Total luminous output	3600 lm

### MAC 101 CLD

Light source	36 cold white (6700 K) Cree XP-E high power emitters
Total luminous output	4500 lm

### All models

Minimum LED lifetime	50 000 hours (to >70% luminous output)*
----------------------	---

\*Manufacturer's figure obtained under manufacturer's test conditions

## Control and Programming

### MAC 101 RGB

DMX control options	3 control modes (RGB raw/calibrated, RGB + CTC enabled/disabled)
DMX channels	8/12

### MAC 101 CT

DMX channels	10
--------------	----

### MAC 101 WRM and MAC 101 CLD

DMX channels	7
--------------	---

### All models

Control protocol	USITT DMX512/1990
Control resolution	8-bit, with 16-bit control of pan & tilt
Setting and addressing	Control panel with backlit graphic display
Transceiver	RS-485
Firmware update	Via DMX with Martin USB Duo DMX Interface

### Construction

Color	Black
Housing	High-impact flame-retardant thermoplastic
Protection rating	IP 20

### Installation

Mounting points	One M12 threaded hole for rigging clamp
Orientation	Any
Minimum distance to combustible materials	100 mm (3.9 in.) from head, no min. distance from base
Minimum distance to illuminated surfaces	200 mm (7.9 ins.)
Location	For indoor use only, must be fastened to fixed surface or structure

### Connections

AC power input	Neutrik PowerCon NAC3MPA input socket (blue)
AC power throughput	Neutrik PowerCon NAC3MPB output socket (grey)
DMX data in/out	5-pin locking XLR

### Electrical

AC power	100-240 V nominal, 50/60 Hz
Typical total power consumption	123 W
Power supply unit	Auto-ranging electronic switch mode
Standby power	<25 W

### Typical Power and Current

100 V, 50 Hz	122 W, 1.3 A, PF 0.991
120 V, 60 Hz	121 W, 1.1 A, PF 0.987
208 V, 60 Hz	123 W, 0.7 A, PF 0.938
230 V, 50 Hz	123 W, 0.6 A, PF 0.915
240 V, 50 Hz	123 W, 0.6 A, PF 0.900

*PF = power factor. Measurements made at nominal voltage with all LEDs at full intensity. Allow for a deviation of +/- 10%.*

### Thermal

Cooling	Forced air (temperature-regulated, low noise, user-definable levels)
Maximum ambient temperature (Ta max.)	40° C (104° F)
Minimum ambient temperature (Ta min.)	5° C (41° F)
Total heat dissipation (calculated, +/- 10%)	420 BTU/hr.

### Approvals

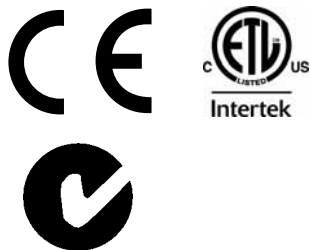

EU safety	EN 60598-2-17 (EN 60598-1), EN 62471
EU EMC	EN 55103-1, EN 55103-2, EN 55015, EN 61547
US safety	UL 1573
US EMC	FCC Part 15 Class A
Canadian safety	CSA E598-2-17 (CSA E60598-1)
Canadian EMC	ICES-003 Class A
Australia/NZ	C-TICK N4241

### Included Items

User manual	P/N 35000246
M12 bolt suitable for use with Martin rigging clamps	



## Accessories

Set of 8 x medium-angle diffusers for MAC 101 . . . . .	P/N 91616018
Set of 4 x top hats for MAC 101 . . . . .	P/N 91611358
Set of 5 x quick-mount surface mounting brackets for MAC 101 . . . . .	P/N 91606017
Neutrik PowerCon NAC3FCA power input connector, cable mount, blue . . . . .	P/N 05342804
Neutrik PowerCon NAC3FCB power output connector, cable mount, light grey . . . . .	P/N 05342805
G-clamp . . . . .	P/N 91602003
Half-coupler clamp . . . . .	P/N 91602005
Quick trigger clamp . . . . .	P/N 91602007
Safety wire, 50 kg safe work load . . . . .	P/N 91604003
8-unit flightcase for 8 x MAC 101™ . . . . .	P/N 91515010

## Related Items

Martin USB Duo DMX Interface Box™ . . . . .	P/N 90703010
---	--------------

## Ordering Information

MAC 101™ (RGB model) in cardboard box . . . . .	P/N 90231600
MAC 101™ (RGB model) in 8-unit flightcase . . . . .	P/N 90231610
MAC 101™ CT in cardboard box . . . . .	P/N 90231620
MAC 101™ CT in 8-unit flightcase . . . . .	P/N 90231625
MAC 101™ WRM in cardboard box . . . . .	P/N 90231650
MAC 101™ WRM in 8-unit flightcase . . . . .	P/N 90231640
MAC 101™ CLD in cardboard box . . . . .	P/N 90231670
MAC 101™ CLD in 8-unit flightcase . . . . .	P/N 90231660

*Specifications subject to change without notice. For the latest product specifications, see [www.martin.com](http://www.martin.com)*

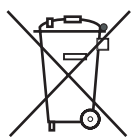

#### **Disposing of this product**

Martin™ products are supplied in compliance with Directive 2002/96/EC of the European Parliament and of the Council of the European Union on WEEE (Waste Electrical and Electronic Equipment), as amended by Directive 2003/108/EC, where applicable.

Help preserve the environment! Ensure that this product is recycled at the end of its life. Your supplier can give details of local arrangements for the disposal of Martin products.





---

[www.martin.com](http://www.martin.com) • Olof Palmes Allé 18 • 8200 Aarhus N • Denmark  
Tel: +45 8740 0000 • Fax +45 8740 0010